



HL7071 Surface Mount Power Divider (DC to 30 GHz)

Features and Technical Specifications

PRODUCT SUMMARY

The HL7071 is a surface mountable (SMD) power divider that provides outstanding amplitude- and phase-symmetrical power division from DC to over 30 GHz (3 dB).

This product is designed using a three-resistor network resulting in outputs that are nominally attenuated to 6 dB, and all ports are impedance-matched to 50 Ohms when the ports are terminated.

They are suitable for use in 100 Gbps Ethernet, 100 Gbps Long Haul, and 40 Gbps (D)QPSK communications systems, high-speed analog-to-digital conversion, frequency response testing for differential devices, and many other applications.

DEPLOYMENT NOTES

The HL7071 is packaged in a leadless 4 x 4 mm surface mount package.

MODELS

HL7071 - SMD package

HL7071-EVAL - mounted to evaluation board

| | |
|---------------------|--|
| Bandwidth (-0.5 dB) | DC to 30 GHz |
| Insertion Loss | 6 dB |
| Amplitude Match | ± 0.3 dB See Fig. 1 |
| Phase Match | $\pm 6^\circ$, $f = 20$ GHz See Fig. 4 |
| Return Loss | > 15 dB, $f \leq 20$ GHz > 10 dB, $f > 20$ GHz See Fig. 2 |
| Rise Time | 12 ps |
| Group Delay | 35 ps, all ports See Fig. 3 |
| Max Input Power | +27 dBm |
| Impedance | $50 \Omega \pm 5\%$ |
| Interface | Solderable pads, Gold ENIG |
| Reflow Profile | Designed to be compatible with a SAC305 thermal reflow profile: - max reflow time above 217 C is 90 seconds - peak reflow temperature is 245 C, not to be exceeded |
| Dimensions | 28 lead 4 x 4 mm SMT package; 16 mm ² See Fig. 5 |
| Temperature Limits | -40° to +85° C, operating |
| RoHS Compliant | Yes |
| REACH Compliant | Yes |
| Warranty | 1 year, see website |

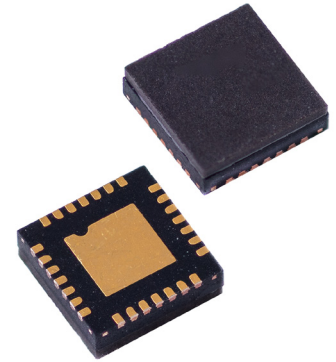

HL7071 4 x 4 mm QFN Package, 28 pin

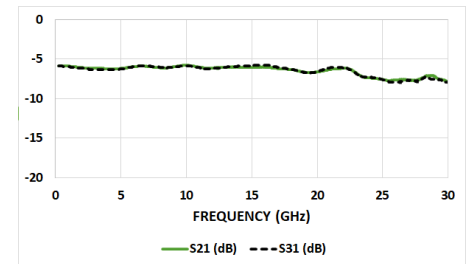

Typical HL7071 Insertion Loss

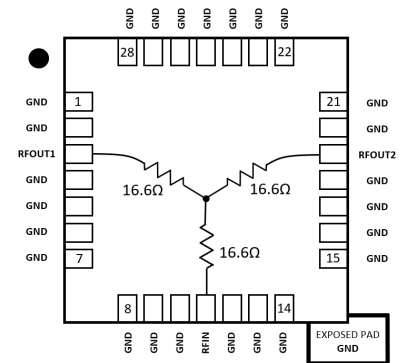

HL7071 Schematic and Port Assignments



HL7071 Insertion and Return Loss

Figure 1 shows the HL7071 insertion loss and amplitude match on RFIN to the RFOUTS to 30 GHz. Figure 2 shows return loss on all three ports of the same device to 30 GHz.

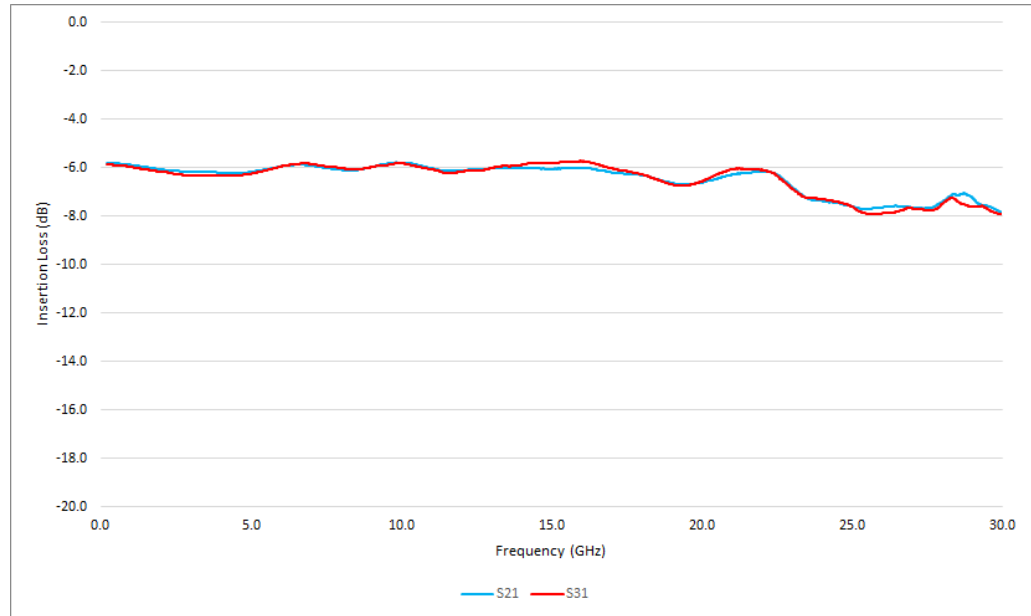

Figure 1: HL7071 Insertion Loss

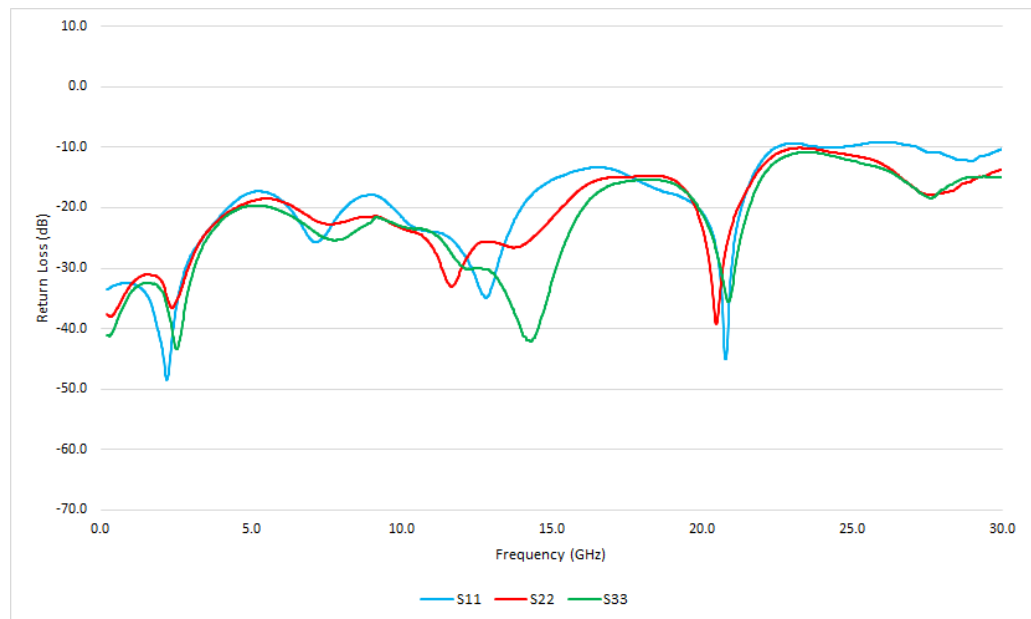

Figure 2: HL7071 Return Loss



HL7071 Group Delay and Phase Match

Figure 3 shows the typical group delay of an HL7071. The average slope of the phase mismatch, shown in Figure 4, is equal to the group delay mismatch.

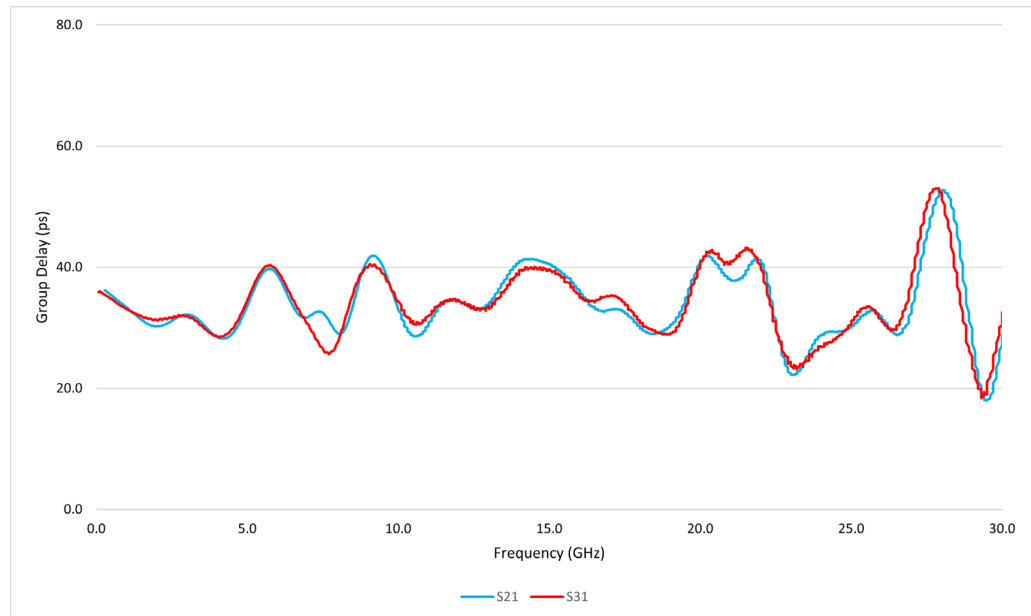

Figure 3: HL7071 Group Delay

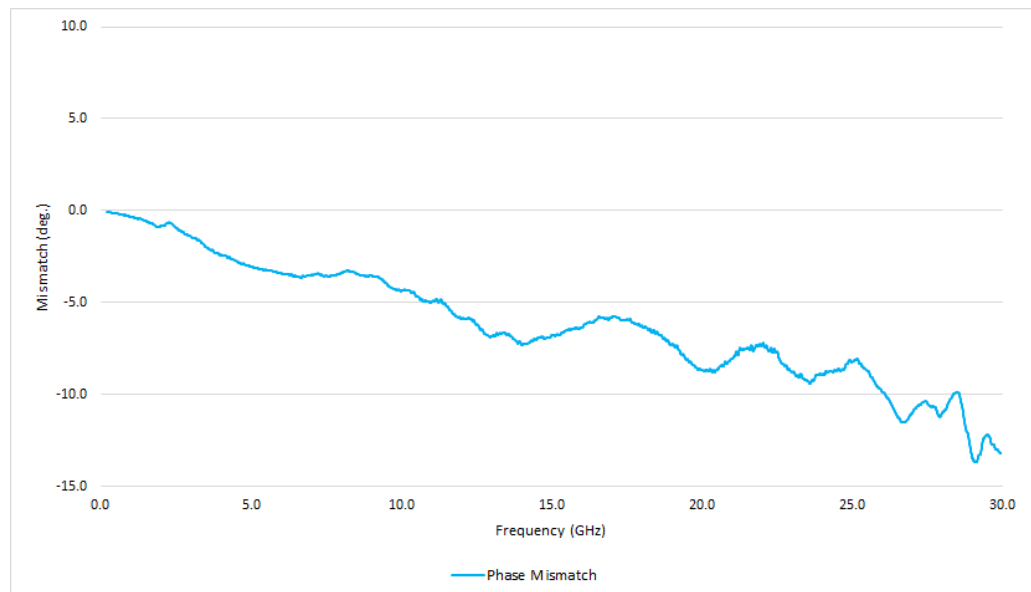

Figure 4: HL7071 Phase Mismatch

HL7071 Dimensional Drawing

Figure 5 shows a mechanical drawing of an HL7071. Figure 6 shows an HL7071 mounted to the evaluation board. Unless otherwise noted, all units are shown in mm.

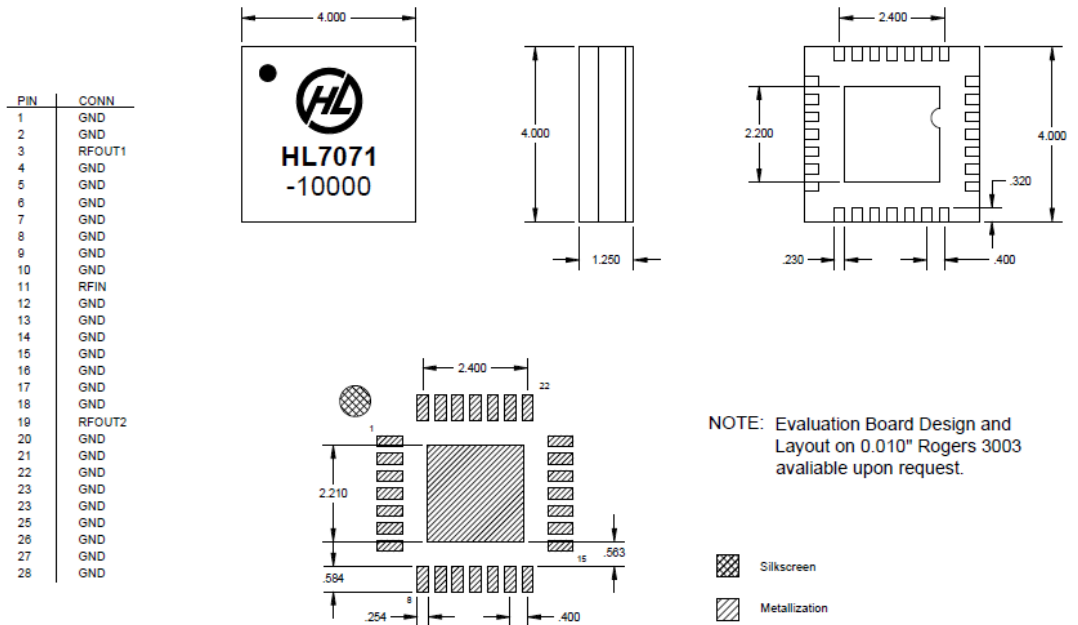

Figure 5: HL7071 Mechanical Drawing

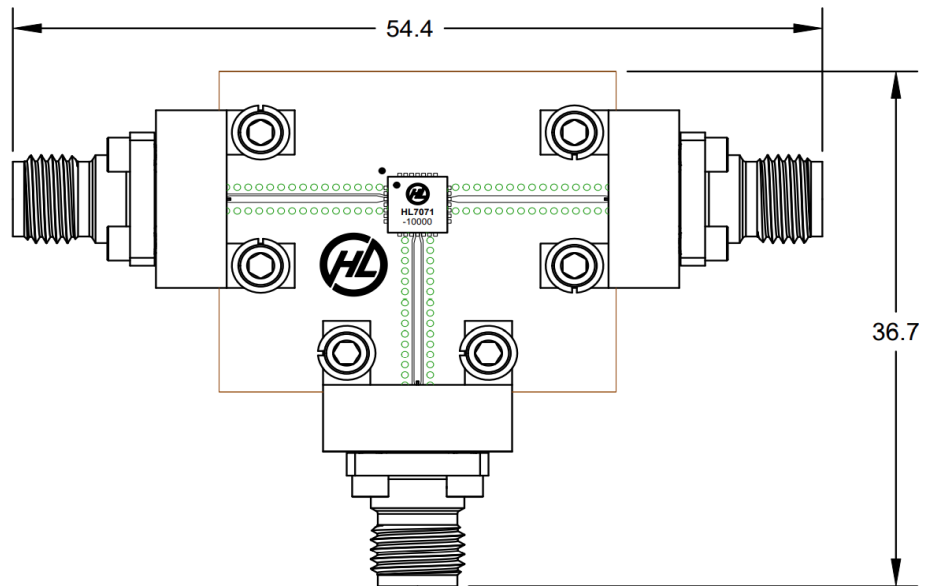

Figure 6: HL7071 Evaluation Board Dimensions