

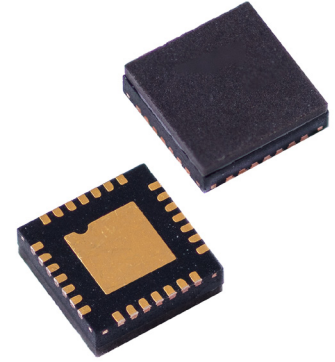

HL9334 Sampler / Harmonic Mixer IC (Preliminary)

Features and Technical Specifications

RF Bandwidth (typical)	DC to 17 GHz (-3dB) DC to 19 GHz (-6dB)
LO Input Frequency, Square Wave	1 GHz to 7 GHz $t_r/t_f = 50$ ps (20-80%) max
LO Input Amplitude, Square Wave	300 mV _{pp} (600 mV _{pp} Diff) minimum
IF Bandwidth (typ.)	DC to 1 GHz (-3 dB)
Conversion Loss (LO = 2 GHz)	20 dB
LO to RF Isolation*	70 dB
Linearity, Second Harmonic Distortion**	-68 dBc
Linearity, Third Harmonic Distortion**	-66 dBc
Input IP3 (typ.)	28 dBm
Input Noise Floor	-130 dBm/Hz
Power Supplies	+6.0 V, 175 mA (VDD) +2.5 V, 110 mA (+2.5V) -5.0 V, 320 mA (VSS) +/- 5% Voltage Tolerance
Power Dissipation	3.0 W
Max Input Power	+15 dBm
Dimensions	4.0 x 4.0 x 1.25 mm, 28 lead QFN
Packaging	Gel-Pak
Case Temperature	+85 °C, max operating +245 °C, for 90 seconds max processing
RoHS Compliant	Yes
REACH Compliant	Yes



HL9334 4 x 4 mm QFN Package, 28 pin

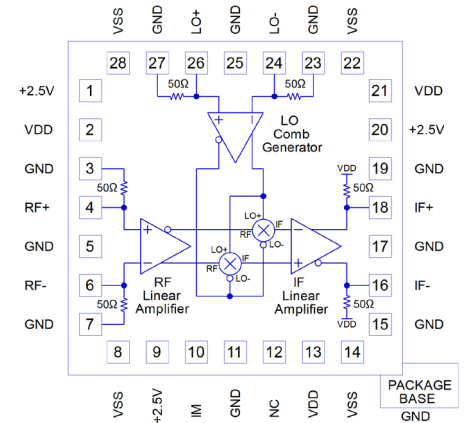

HL9334 Port Assignments

PRODUCT SUMMARY

The HL9334 is a high-precision sampler / harmonic mixer integrated circuit offering excellent linearity, low noise and flat frequency response up to 20 GHz (RF).

APPLICATIONS

- Harmonic down conversion
- High-speed front-end for A/D converters
- Use in network analyzers, TDRs, sampling oscilloscopes, and spectrum analyzers
- Reference design eval boards available

OPTIONS

The following options are available:

- HL9334**- SMD package
- HL9334-EVAL-MA** - mounted to eval board with MACOM balun (2-18 GHz)
- HL9334-EVAL-HL** - mounted to eval board with HYPERLABS balun (1 MHz to 20 GHz)

EXPORT RESTRICTIONS

An export license may be required to purchase this product from outside of the United States. Please contact HYPERLABS for more information.

* NOTE: Assumes LO driven at 0 dBm through recommended limiting amplifier.

** NOTE: Harmonic distortion measurements taken under test conditions: LO = 2 GHz square wave, RF = 100 MHz @ 0 dBm



HL9334 Downconversion Loss

Figure 1 shows the typical downconversion loss (dB) at IF = 100 MHz.

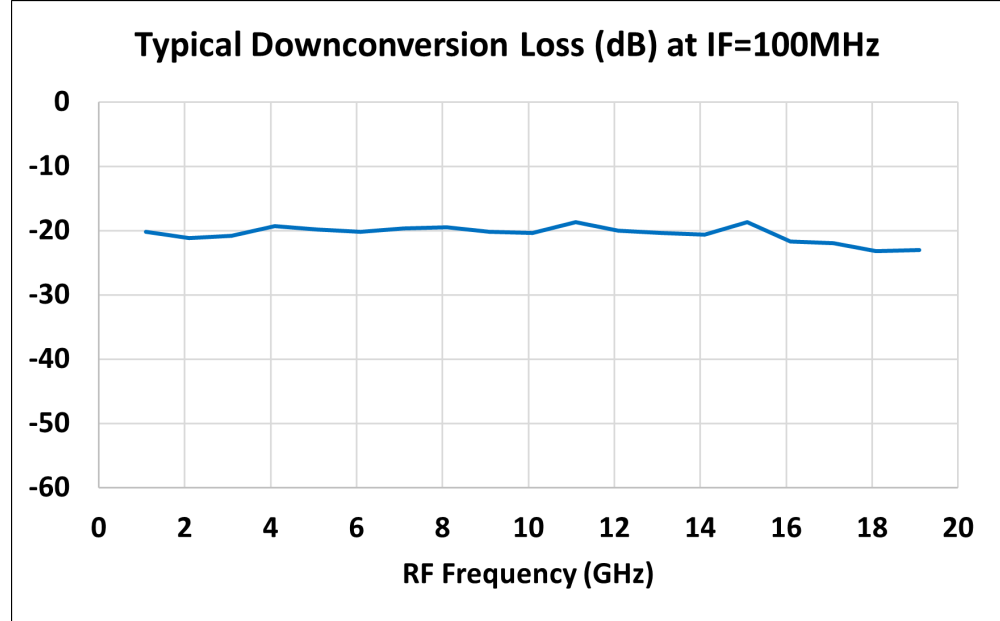

Figure 1: HL9334 Conversion Loss
Measured at LO = 2 GHz, IF = 100 MHz, -10 dBm RF Input Power

HL9334 Downconversion Harmonic Distortion

Figure 2 shows the typical downconversion harmonic distortion (dBc) at IF = 100 MHz.

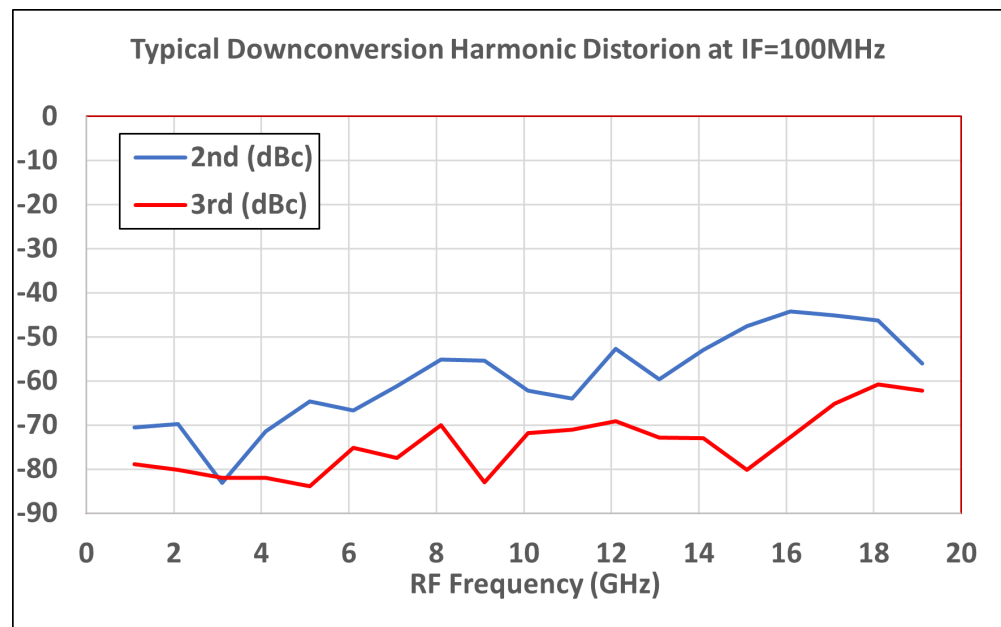

Figure 2: HL9334 Harmonic Distortion
Measured at LO = 2 GHz, IF = 100 MHz, -10 dBm RF Input Power