



HL9452 Transition Time Converters (1-15 GHz)

Options and Technical Specifications

PRODUCT SUMMARY

The HL9452 family of Transition Time Converters is based on low-pass absorptive rise time filters to provide superior return loss and flat group delay at frequencies from 1 to beyond 15 GHz.

Designed using a proprietary absorptive filtering, these filters offer similar frequency response as 4th order Bessel-Thompson filters.

These filters are suitable for OEM use in high-speed telecom and digital networks, as anti-aliasing filters in digital oscilloscopes, and to limit the RF bandwidth to known values.

DEPLOYMENT NOTES

All specifications contained herein are typical unless otherwise noted.

S-parameter files and higher resolution versions of the plots on the following pages are available on our website.

These devices are bidirectional.

CUSTOM FILTERS

In addition to the options listed in this datasheet, HYPERLABS offers customers quick-turn custom filter designs up to 45 GHz.

The full-turn service includes design, manufacturing, and assembly and small quantities are typically available within a few weeks.

Please contact us for more information about these custom designs.

Option	Rise Time	Bandwidth (-3 dB fc)
-24	24 ps	14.5 GHz
-25	25 ps	14 GHz
-27	27 ps	13 GHz
-28	28 ps	12.5 GHz
-29	29 ps	12 GHz
-33	33 ps	10.6 GHz
-47	47 ps	7.46 GHz
-60	60 ps	5.83 GHz
-100	100 ps	1 GHz
-150	150 ps	3.5 GHz
-200	200 ps	2.33 GHz
-350	350 ps	1.75 GHz
-xxx	Custom	Custom

Common Specifications

Insertion Loss ~0.07 to 0.24 dB (varies by option)
See full specifications on pg. 2

Group Delay (100 MHz to fc) ~270 ps
See Fig. 2 below

Return Loss (DC to 3 fc) ~17 dB (varies by option)
See Fig. 4 below

Max Input Power 1 W

Impedance 50 Ω

Connectors SMA, Jack/Plug (standard)
Other configurations available upon request for additional charge

Dimensions 1.80" x 0.60" x 0.40"
45.72 x 15.24 x 10.16 mm

Weight 14 g (0.49 oz.)

Temperature Limits -40° to +40° C, operating

RoHS Compliance RoHS compliant; made with lead-free solder

Warranty 1 year, see website



HL9452

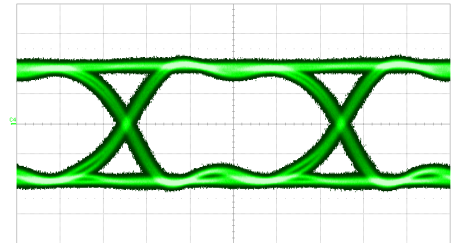

16 Gbps PRBS31 pattern at RF Input of HL9452-28; see also Figs. 5-6 below

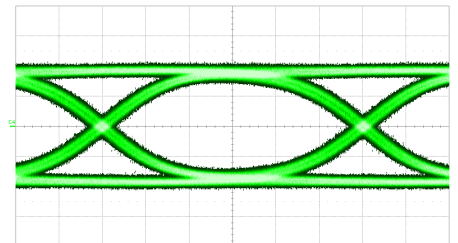

16 Gbps PRBS31 pattern at RF Output of HL9452-28

HL9452 Full Specifications

Option	Rise Time	Bandwidth (-3 dB fc)	Insertion Loss (dB)	Return Loss (dB)	Group Delay (ps)
-24	24 ps	14.5 GHz	0.07	15	268
-25	25 ps	14 GHz	0.07	18	268
-27	27ps	13 GHz	0.08	16	269
-28	28 ps	12.5 GHz	0.08	17	271
-29	29 ps	12 GHz	0.07	19	269
-33	33 ps	10.6 GHz	0.1	17	273
-47	47 ps	7.46 GHz	0.1	15	262
-60	60 ps	5.83 GHz	0.11	20	267
-100	100 ps	3.5 GHz	0.15	20	286
-150	150 ps	2.33 GHz	0.2	19	283
-200	200 ps	1.75 GHz	0.24	20	329
-350	350 ps	1 GHz	0.03	16	511

Parameter	Common Specifications	Comments
Max Input Power	1 W (+30 dBm)	
Impedance	50 Ω	Input and Output
Connectors	SMA, Jack/Plug (standard) Other configurations available upon request for additional charge	
Dimensions (W x D x H)	1.80" x 0.60" x 0.40" 45.72 x 15.24 x 10.16 mm	Package including connectors
Weight	14 g (0.49 oz.)	
Operating Temp.	-40° to +70° C	Case temperature
RoHS Compliant	Yes, assembled with lead-free solder	
REACH Compliant	Yes	
Warranty	1 year, repair or replacement; see website for details	

HL9452 Rise Time and Group Delay

Figure 1 shows the 1 V step response for various HL9452 options. Figure 2 shows the group delay (ps) over the operating frequency range of these same options.

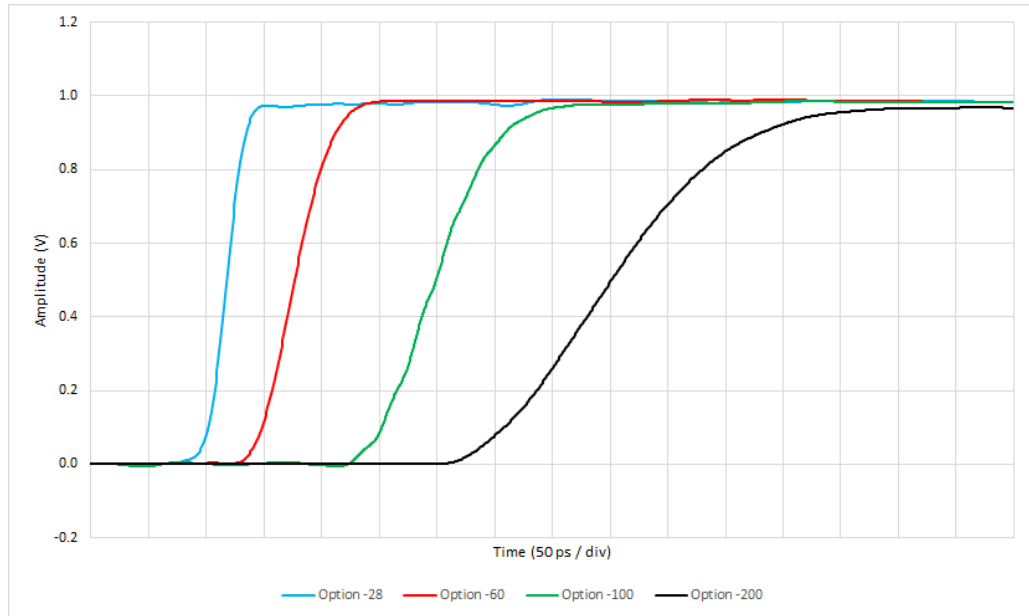

Figure 1: Typical HL9452 step response, various options

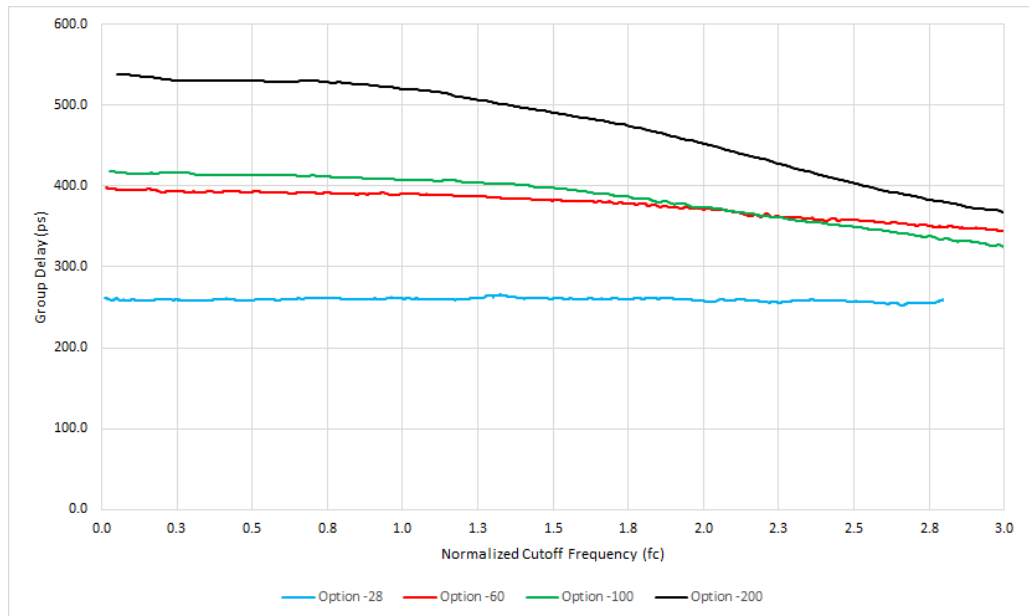

Figure 2: Typical HL9452 group delay, various options



HL9452 Insertion Loss and Return Loss

Figure 3 shows the Insertion Loss and Figure 4 shows the Return Loss on various HL9452 options over the operating frequency range.

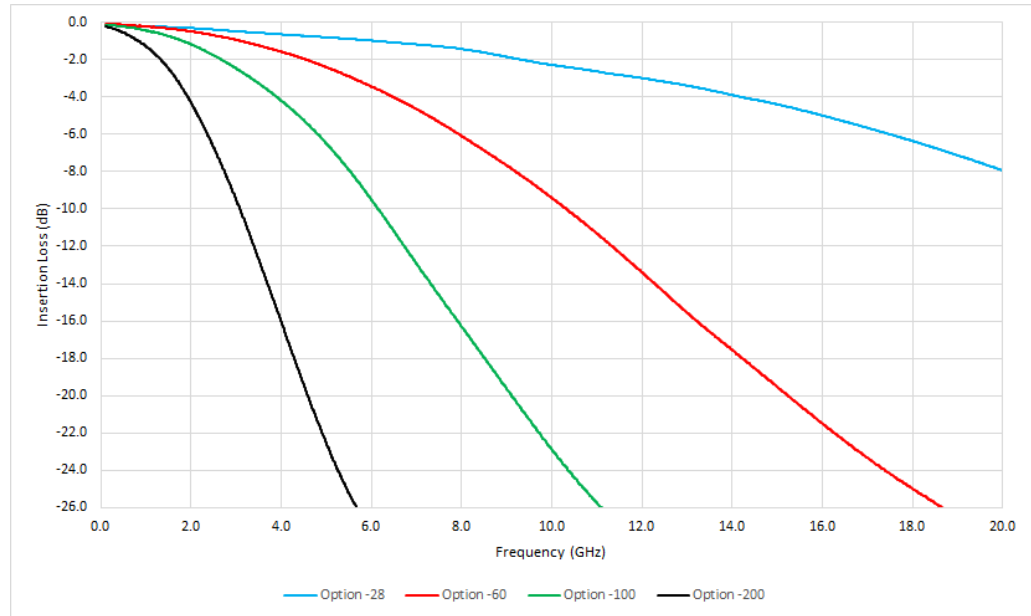

Figure 3: Typical HL9452 insertion loss, various options

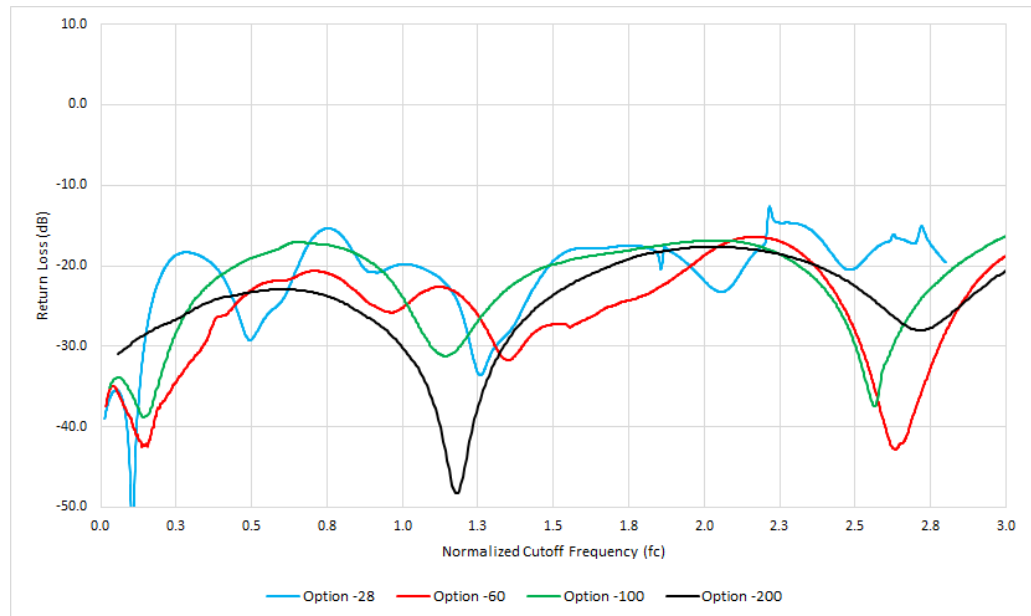

Figure 4: Typical HL9452 return loss, various options



HL9452 Eye Diagrams

Figure 5 shows a 16 Gbps PRBS31 pattern on the RF Input of option HL9452-28 and Figure 6 shows the same pattern at the RF Output.

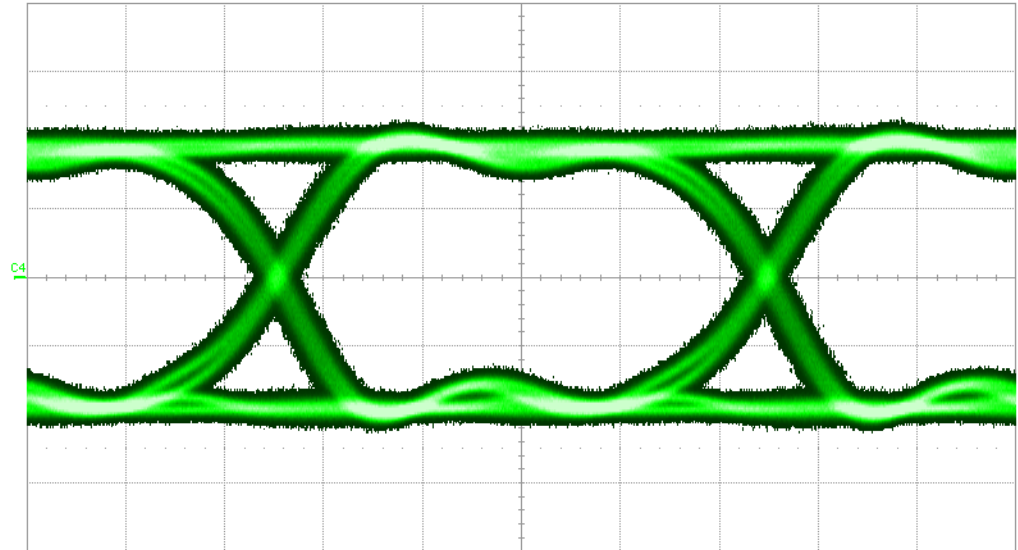

Figure 5: Typical eye diagram of a 16 Gbps PRBS31 pattern on option HL9452-28, RF In

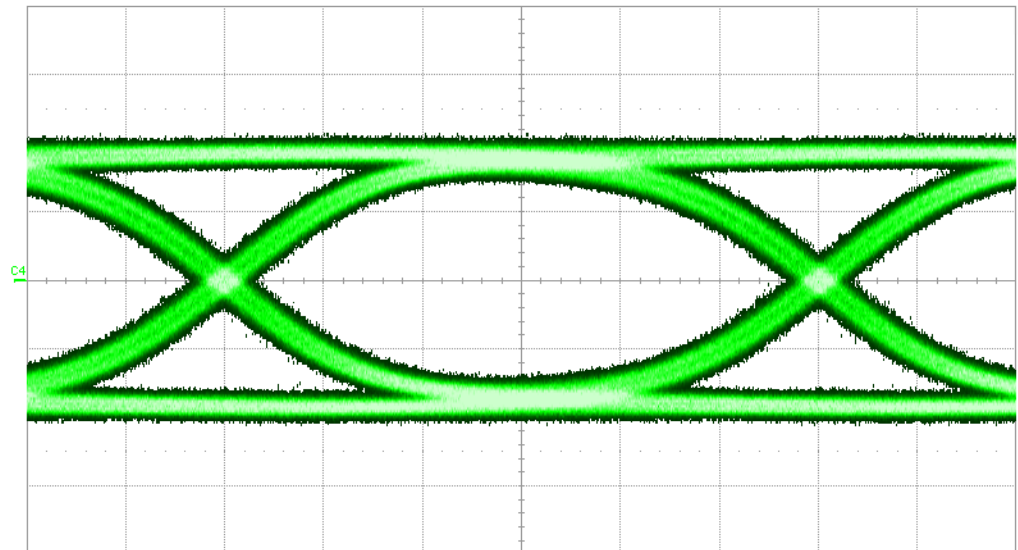

Figure 6: Typical eye diagram of a 16 Gbps PRBS31 pattern on option HL9452-28, RF Out



HL9452 Dimensional Drawing

Figure 8 shows a mechanical drawing of an HL9452. Unless otherwise noted, all units are in inches. See page 2 for full dimensions.

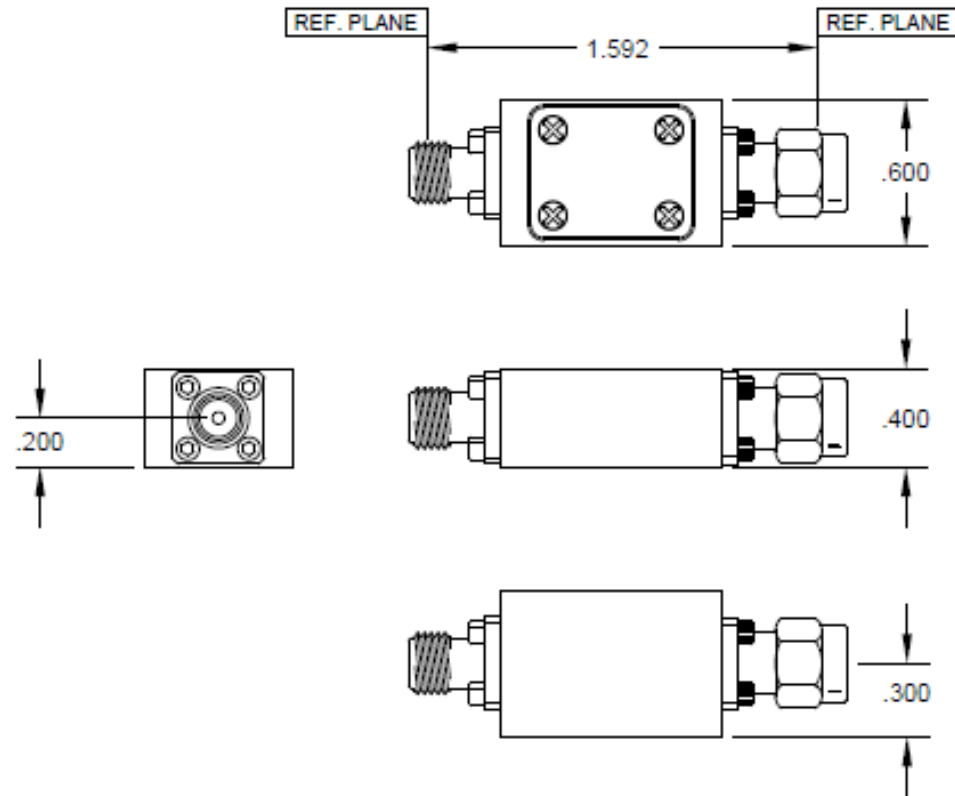

Fig 8: HL9452 Mechanical Drawing