



HL948x Series Resistive Power Splitter (DC to 67 GHz)

Features and Technical Specifications¹ (HL9487 shown)

PRODUCT SUMMARY

The HL948x series are ultra-broadband, symmetrical, two-resistor power splitters that provide outstanding amplitude and phase-symmetrical power division from DC to beyond 67 GHz. The splitters also provide exceptional band flatness and return loss across the frequency range.

These parts are suitable for making power ratio measurements as accuracy of the divided outputs is extremely well tracked. The precision of the divided outputs allows for measurements to be taken with a high level of ratio-metric certainty.

They are applicable for levelling applications in transmission measurements, or reflection measurements with the use of a bridge.

DEPLOYMENT NOTES

If used in the reverse direction, the device can be used as a combiner.

MODELS & OPTIONS

The following models are available:

- HL9482, 26.5 GHz
- HL9484, 40 GHz
- HL9485, 50 GHz
- HL9487, 67 GHz

Bandwidth (-1.5 dB)	DC to 67 GHz
Insertion Loss (AC)	6 dB
Amplitude Match	± 0.1 dB See Fig. 1
Phase Match	$\pm 4^\circ$, $f = 20$ GHz $\pm 8^\circ$, $f = 40$ GHz See Fig. 4
Return Loss - Input port 1	> 18 dB, $f \leq 50$ GHz See Fig. 2
Rise Time	5 ps
Insertion (Group) Delay	130 ps, all ports See Fig. 3
Max Input Power	+27 dBm
Impedance	$50 \Omega \pm 5\%$
Connectors	1.85 mm, 3x jack/female
Dimensions	0.69" (17.6 mm), center to end of each connector See Fig. 9
Temperature Limits	-40° to $+70^\circ$ C, operating
RoHS Compliant	Yes, assembled with lead-free solder
REACH Compliant	Yes
Warranty	1 year, see website

NOTE 1 - Unless otherwise noted, the specifications in this table are typical for Model Number HL9487. Full specifications for this and related models are available on Page 2 of this datasheet.

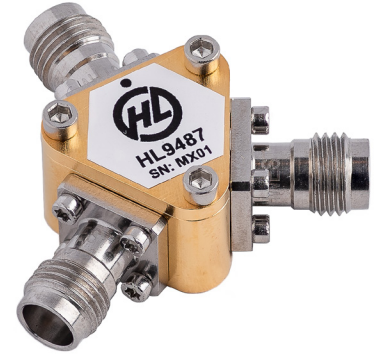

HL9487, standard configuration shown

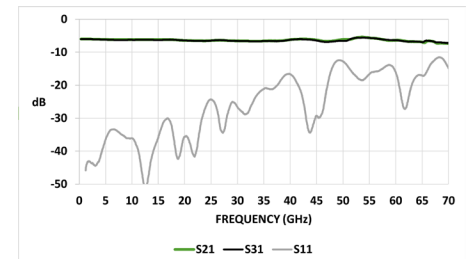

Typical HL9487 Insertion and Return Loss

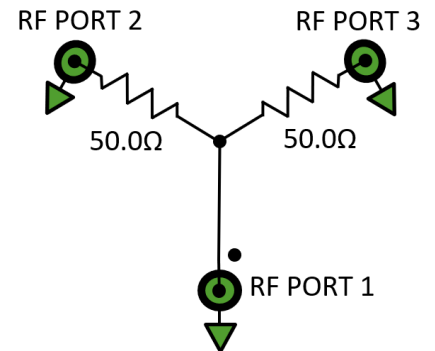

HL948x Schematic and Port Assignments

HL948x Full Specifications

Parameter	HL9482	HL9484	HL9485	HL9487	Comments
Upper Frequency Limit	26.5 GHz	40 GHz	50 GHz	67 GHz	1.5 dB guaranteed, relative to nominal insertion loss
Lower Frequency Limit	DC				
Insertion Loss (DC)	6.02 ± 0.11 dB				
Insertion Loss (AC) See Fig. 1	6 dB				Typical, nominal
Return Loss Input Port 1 See Fig. 2	> 20 dB	> 18 dB	> 18 dB	> 18 dB, f ≤ 50 GHz > 12 dB, f > 50 GHz	Typical
Return Loss Output ports 2 and 3 See Fig. 2	> 10 dB	> 10 dB	> 10 dB	> 10 dB	Typical
Amplitude Match See Fig. 1	± 0.1 dB				Typical, between all ports
Phase Match See Fig. 4	± 4°, f = 20 GHz	± 4°, f = 20 GHz ± 8°, f = 40 GHz	± 4°, f = 20 GHz ± 8°, f = 40 GHz	± 4°, f = 20 GHz ± 8°, f = 40 GHz	Typical, between all ports
Rise Time	17.5 ps	8.75 ps	7 ps	5.2 ps	Typical
Insertion (Group) Delay See Fig. 3	130 ps				Typical, all ports
Max Input Power	+27 dBm				Subject to change
Impedance	50 Ω ± 5%				Only input port
Connectors	SMA, 3x jack/female	2.92 mm, 3x jack/female	2.4 mm, 3x jack/female	1.85 mm, 3x jack/female	Plug/male connectors available upon request
Length and Width	0.69" 17.57 mm				From center to reference plane of each connector
Height	0.535" 13.59 mm				
Weight	14 g (0.49 oz.)				
Operating Temperature	-40° to +70° C				Case temperature
RoHS Compliant	Yes, assembled with lead-free solder				
REACH Compliant	Yes				
Warranty	1 year, repair or replacement; see website for details				

中国区(含香港)代理 南京舜特科通信技术有限公司

地址: 南京市江宁区胜利路89号紫金研创中心5号楼1004

电话/传真: 025-52635773/52632557

官网: www.sainty-tech.com



HL948x Insertion and Return Loss

The HL9487 is matched to 50 Ω on all ports. Port 1 is specified with a dot on the label, and Ports 2 and 3 are matched.

Figure 1 shows the HL9487 insertion loss and amplitude match on Ports 2-3 to 70 GHz. Figure 2 shows return loss on all three ports of the same device to 70 GHz. Other models show similar performance within their respective specified bandwidths.

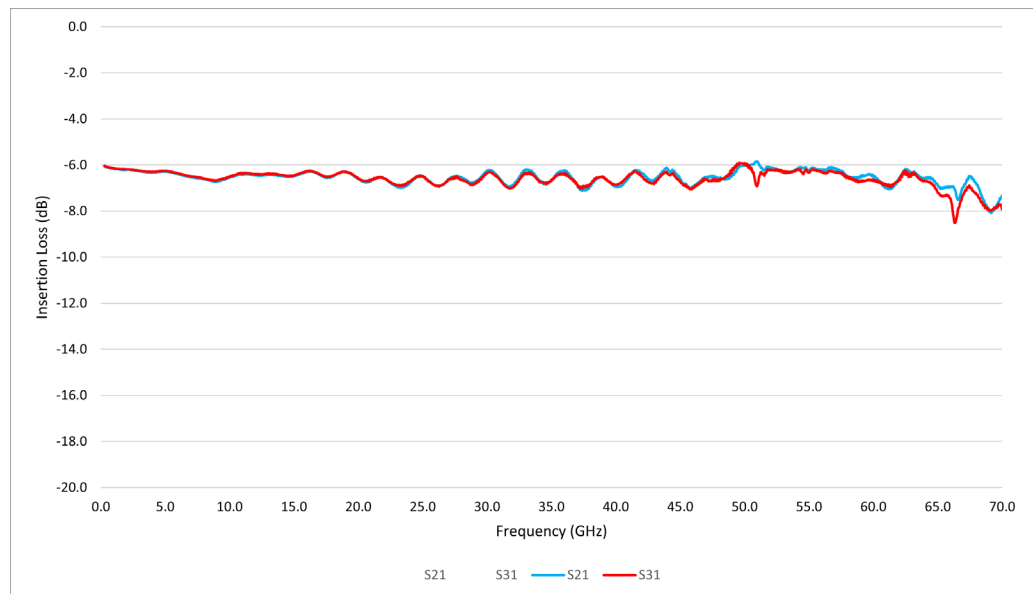

Figure 1: HL9487 Insertion Loss

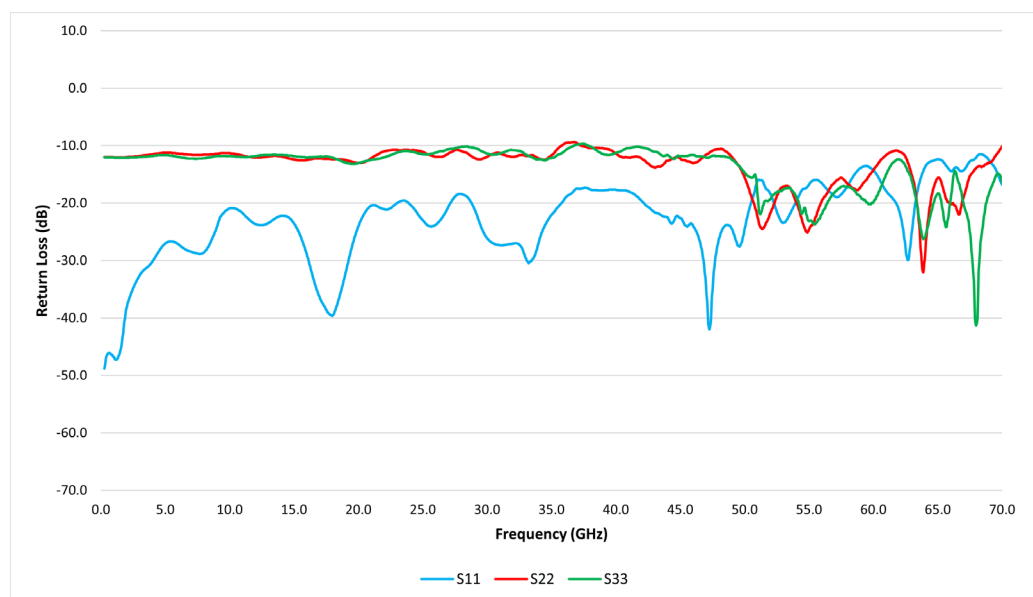

Figure 2: HL9487 Return Loss



HL948x Group Delay and Phase Match

Figure 3 shows the typical group delay of an HL9487. The average slope of the phase mismatch, shown in Figure 4, is equal to the group delay mismatch. Other models show similar performance within respective specified bandwidths.

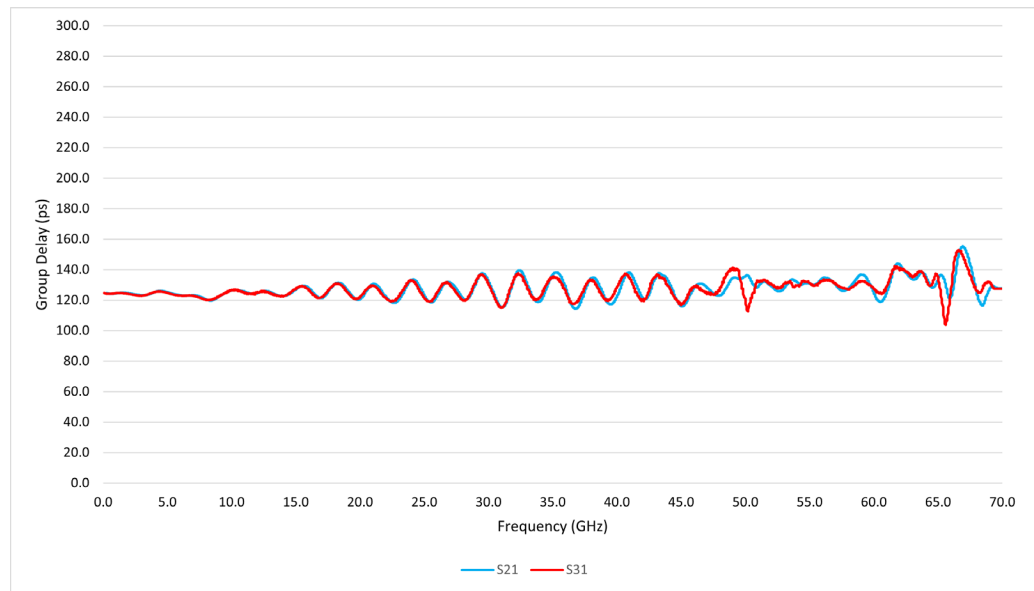

Figure 3: HL9487 Group Delay

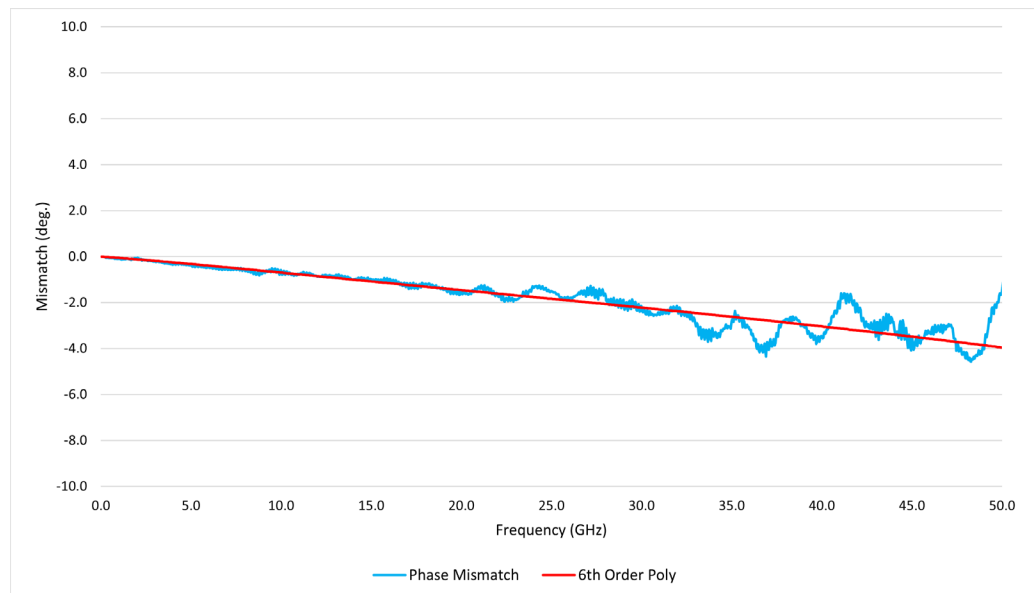

Figure 4: HL9487 Phase Mismatch



HL948x Dimensional Drawing

Figure 5 shows a mechanical drawing of an HL9487. Unless otherwise noted, all units are shown in inches. Other models vary in length and width based on connectors.

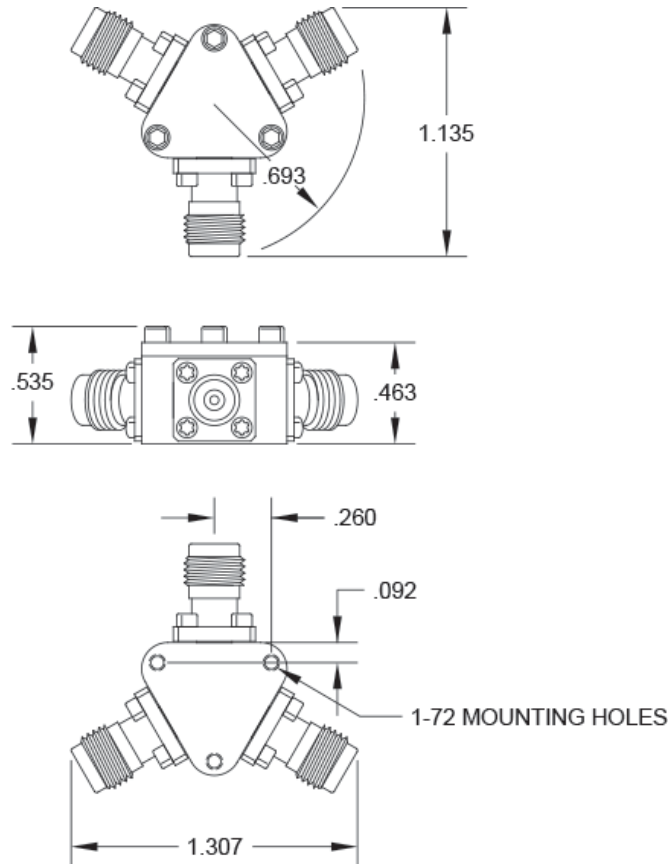

Figure 5: HL9487 Mechanical Drawing